

GOLF PLUS

Under pressure threaded coupling branch tee

REFERENCE SPECIFICATIONS

Grid	Water
Highest operating pressure	16 bar
Pipe material	Steel, Asbestos cement, Ductile iron, PE and PVC-O
Pipe outer diameter	70 to 355 mm
Outlet size	Female thread GAS 1", 1¼", 1½" and 2"



Applications

Threaded coupling branch tee for under pressure branching to be installed on steel, asbestos cement and ductile iron pipes for pressure up to 16 bar in water. These are also used with excellent results on polyethylene and PVC-O pipe networks.

Drinking water certificated

Torre® saddles are equipped with EPDM joints certified for use with drinking water under WRAS: "Water Regulations Advisory Scheme" and under ACS: "Attestation de Conformité Sanitaire".

Highest corrosion resistance

The whole branch tee results electrically insulated, consequent to the component materials, thus avoiding galvanic corrosion. Straps incorporate welding free manufacturing technique to avoid inter-granular corrosion.

Spatula shut off

To carry out the under pressure connection operation the water flow is interrupted by means of inserting the stainless steel spatula supplied with the Golf equipment.

Highest tightness

Golf Plus provides highest tightness for pressurised service connections since two additional external O-rings and sleeve enhance the inner seal effectiveness for maximum safety and reliability.

Convenient installation

Compact design of Torre® drilling tool and strap anchoring system, both enable to install Golf branch tees in restricted access spaces in any vertical, horizontal or inclined position.

Capping off service connections

Moving the sleeve upwards and inserting the stainless steel spatula, repair work can be carried out on the service connection network or the tapping can be capped off by means of inserting a threaded plug.

Storage advantages

Saddles and straps alike are supplied in labelled boxes to make handling, storage and identification easier. Each box comes with a brochure including detailed assembly instructions.

GOLF PLUS Under pressure threaded coupling branch tee

Technical data

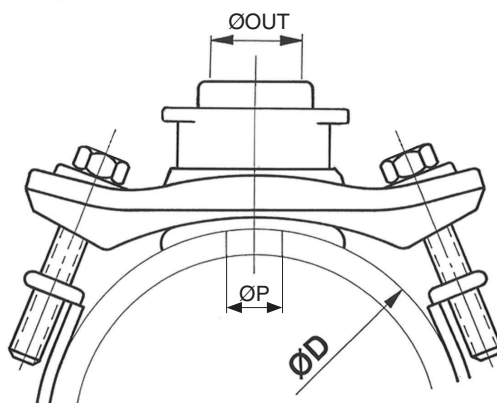

GOLF PLUS BRANCH TEES

OUTLETS, REFERENCES AND APPLICATION RANGE

ØOUT	ØP	REFERENCE	ØD min.	ØD max.	UTS. / BOX
1"	24	2355 S 2C	70	355	10
1¼"	30	2355 S 3C	70	355	10
1½"	38	2355 S 4C	90	355	6
2"	44	2355 S 5C	90	355	6

COMPONENTS MATERIALS

O-RINGS	NBR, Rubber (EN 549)
SLEEVE	PPO + Glass Fiber (NORYL)
SADDLE	Ductile Iron GJS-450-10 + + Epoxi (EN 1563)
SEAL	EPDM, Rubber (EN 681-1)

STRAPS

SIZES, REFERENCES AND APPLICATION RANGE

SIZE	REFERENCE	ØD min.	ØD max.	UTS. / BOX
60	2330 C 060	70	90	5
80	2330 C 080	90	110	5
100	2330 C 100	110	130	5
125	2330 C 125	130	150	5
150	2330 C 150	160	180	5
175	2330 C 175	190	210	5
200	2330 C 200	220	240	5
225	2330 C 225	250	270	5
250	2330 C 250	270	290	5
300	2330 C 300	315	335	5
300L	2330 C 300L	335	355	5

COMPONENTS MATERIALS

ROTULA	Acetal Resin POM
SCREW	AISI304, Stainless Steel (EN 10088)
STRAP	AISI304, Stainless Steel (EN 10088)
RIM	NBR, Rubber