

# GOLF CONNECTOR

Under pressure threaded outlet branch connector

## REFERENCE SPECIFICATIONS

Grid	Water
Highest operating pressure	16 bar
Connection thread	Male thread GAS 1", 1½" and 2"
Outlet size	Female thread GAS 1", 1½" and 2"



### Applications

Connection accessories to be installed on standard collars for convenient under pressure connection, for pressure up to 16 bar in water.

### Drinking water certificated

Torre® connectors are equipped with EPDM joints certified for use with drinking water under WRAS: "Water Regulations Advisory Scheme" and under ACS: "Attestation de Conformité Sanitaire".

### Spatula shut off

To carry out the under pressure connection operation, water flow is interrupted by insertion of a stainless steel spatula supplied with each Golf equipment.

### Highest tightness

Golf connectors provides maximum water-tightness for pressurised service connections since two additional external o-rings and sleeve enhance the inner seal effectiveness for maximum safety and reliability.

### Convenient installation

Compact design of Torre® drilling tool and strap anchoring system, both enable to install Golf connectors in restricted access spaces in any vertical, horizontal or inclined position.

### Storage advantages

Connectors are supplied in labelled boxes to make handling, storage and identification easier.

# GOLF CONNECTOR

Under pressure threaded outlet branch connector

## Technical data

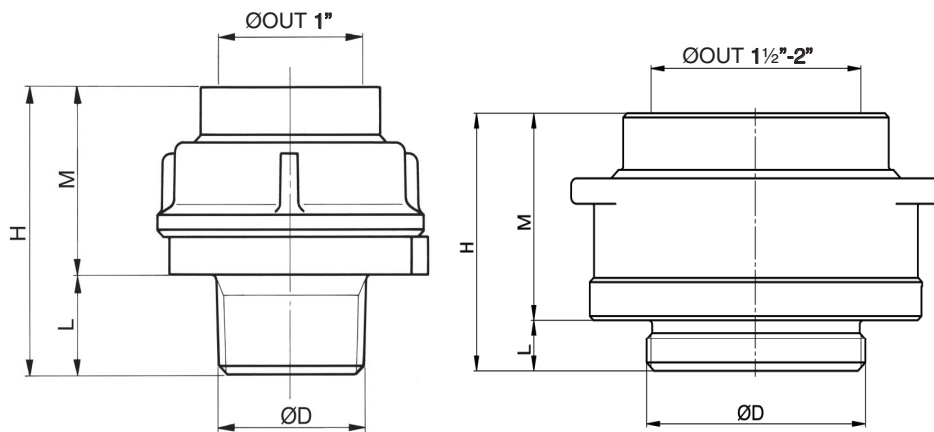

## GOLF CONNECTORS

### OUTLETS, REFERENCES AND SIZES

ØOUT	REFERENCE	ØD	H	M	L
1"	2350 C 2 A	1" gas	54	40	14
1½"	2350 C 4 A	1½" gas	56	42	14
2"	2350 C 5 A	2" gas	62	48	14

### COMPONENTS

### MATERIALS

O-RINGS	NBR, Rubber (EN 549)
NUT	Brass CW617N (EN 12165)
SLEEVE	PPO + Glass Fiber (NORYL)
BODY	Brass CW617N (EN 12165)
SEAL	EPDM, Rubber (EN 681-1)